

SPECTRUM SENSOR

GL SERIES



FEATURES & BENEFITS

- Reliable real-time water quality information
- Multiple wavelength UV-VIS sensor (200-750 nm)
- Wastewater to high purity measurement ranges
- Simple optical measurements, no reagents
- Multiple parameter configuration available
- Parameters include BOD, COD, TOC, DOC, UV254, UVT, TSS, nitrate, nitrite, permanganate, colour

MUNICIPAL DRINKING WATER
MUNICIPAL WASTEWATER
INDUSTRIAL PROCESS WATER
INDUSTRIAL WASTEWATER

WATER QUALITY
MONITORING
SOLUTIONS

REAL-TIME MONITORING SOLUTION

GL Series Spectrum Sensor

Real Tech's GL series bypass sensor provides real-time measurement of organic matter, nitrate and other compounds in water or wastewater. Designed to meet the needs of many monitoring applications, the series offers multiple sensor path length selections for the desired measurement range.

Controllers And Accessories

Our innovative modular product platforms allows a system to be configured around the ideal sensor with controller options and various accessory products, including automatic chemical cleaning systems that lower maintenance while improving system performance and dilution systems that extend the measurement range for highly concentrated wastewaters. We can truly meet the physical demands of any installation, wastewater or high purity, to ensure reliable, continuous operation.

Liquid Ai Compatible

With the right sensor and hardware configuration, we then use custom data analysis and machine learning algorithms to bring true meaning to the data. This technique ensures accuracy and reliability so our clients can have the utmost confidence in their results. The longer our systems are installed, the smarter they become as they continue to learn the characteristics of the site-specific water with our Liquid Ai services.

MEASUREMENT PRINCIPLE

The GL sensor utilizes UV-VIS light for measurement, continuously scanning the water with multiple wavelength, configurable up to 40 between 200-750 nm. The GL series benefits from Real Tech's innovative Split-Sense Pro technology that compensates for lamp drift and fluctuations, providing an accurate and stable output overtime. GL series sensor parameters include BOD, COD, TOC, DOC, UV254, UVT, TSS, NO₃, NO₂, colour, permanganate, contaminant alarms, spectral fingerprint and custom alarms, dependant on application and industry.

REALTECH
INC.



SPECTRUM SENSOR **GL** SERIES SPECIFICATIONS

CHARACTERISTIC	TECHNICAL DATA						
MODEL	GL2010	GL2020	GL2040	GL2080	GL4025	GL4050	GL4150
Path Length	1 mm	2 mm	4 mm	8 mm	25 mm	50 mm	150 mm
Parameters	BOD, COD, TOC, DOC, UV254, UVT, TSS, nitrate, nitrite, permanganate, colour, contaminant alarms, spectral fingerprint, custom alarm						
Range	Depends on model selected. Refer to range chart on next page.						
Units	Parameter specific (mg/L, cm ⁻¹ , % or PCU)						
Sampling Time	1 minute						
Calibration	Zero to DI water. Factory parameter calibration allows field adjustment as required.						
Cleaning	In-situ chemical cleaning makes cleaning quick and easy. Automatic chemical cleaning is optional.						
Self-Diagnostics	Detection and diagnosis of internal system fault						
Alarms	Dry contact terminals allow for operator configurable alarms for: high and low set points, low lamp output, leak detect, system fault, etc.						
Humidity Control	Humidity sensor with large plug-in regenerating desiccant system						
Wavelengths	Configurable up to 40 wavelength between 200-750 nm						
Light Source	Xenon Flash Lamp						
Lamp Life	2-5 years						
Dimensions	19.0"H x 20.5"W x 9.0"D						
Enclosure	NEMA 4, wall mountable						
Flow Rate	300-1000 mL/min						
Pressure Rating	20 PSI						
Fluid Connections	1/4" tube push-in fittings						
Electrical/Comm.	From controller						
Storage Temp.	-20 to 60°C (-4 to 140°F)						
Operating Temp.	0 to 45°C (32 to 113°F)						
Weight	44 lb						
Technology	Split-Sense Pro						
Warranty	2-year limited warranty (Extended care packages available)						
Sensor Upgrades	Cooling Upgrade I, Cooling Upgrade II, Ultra High Temp./Chemical Upgrade, Seawater Upgrade						

* Technical Specifications are subject to change without notice.

DIMENSIONS

GL series sensor is a bypass cabinet instruments installed directly on a wall, railing or system backboard. Sample is supplied to the sensor from either a pressurized source or from an open-channel using an accessory pumping system.

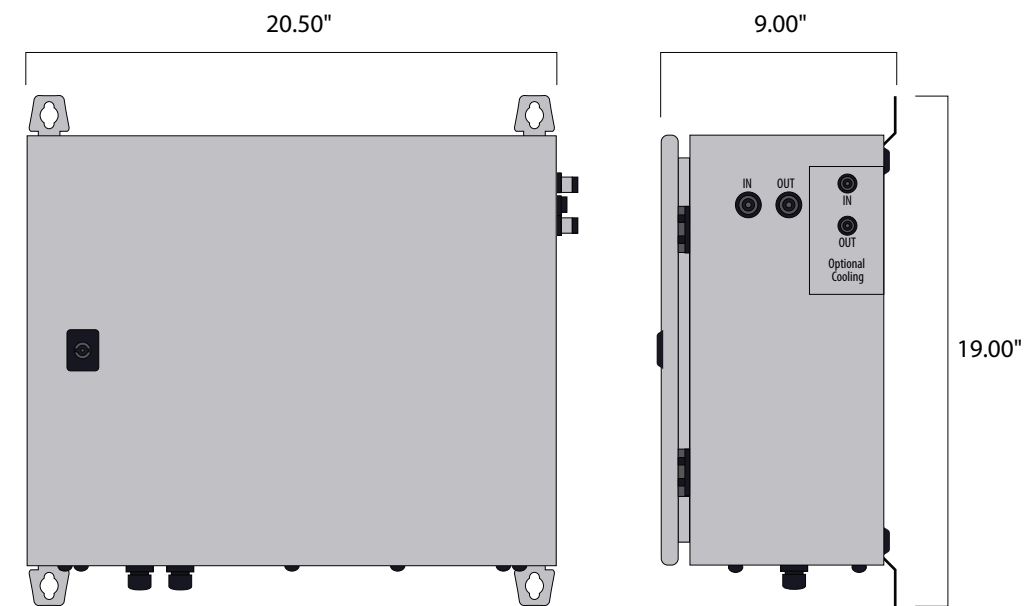

MODELS & RANGE

GL series models include UV-VIS sensor, flow cell, calibration bottle and dehumidifier. Controller and accessories sold separately.

MODEL#	PATH LENGTH	BOD (mg/L)	COD (mg/L)	TOC (mg/L)	DOC (mg/L)	UV254 (cm ⁻¹)	COLOUR (PCU)	NO ₃ -N (mg/L)	NO ₃ (mg/L)	NO ₂ -N (mg/L)
GL2010	1 mm	0 - 1500	0 - 3000	0 - 1200	0 - 800	0 - 20	0 - 6000	0 - 50	0 - 220	0 - 50
GL2020	2 mm	0 - 750	0 - 1500	0 - 600	0 - 400	0 - 10	0 - 3000	0 - 25	0 - 110	0 - 25
GL2040	4 mm	0 - 375	0 - 750	0 - 300	0 - 200	0 - 5	0 - 1500	0 - 12.5	0 - 55	0 - 12.5
GL2080	8 mm	0 - 187	0 - 375	0 - 150	0 - 100	0 - 2.5	0 - 750	0 - 6.25	0 - 27.5	0 - 6.25
GL4025	25 mm	0 - 60	0 - 120	0 - 48	0 - 32	0 - 0.8	0 - 240	0 - 2	0 - 8.8	0 - 2
GL4050	50 mm	0 - 30	0 - 60	0 - 24	0 - 16	0 - 0.4	0 - 120	0 - 1	0 - 4.4	0 - 1
GL4150	150 mm	0 - 10	0 - 20	0 - 8	0 - 5.3	0 - 0.13	0 - 40	0 - 0.33	0 - 1.45	0 - 0.33

* Stated ranges are approximate, dependent on industry, site and application - contact Real Tech to confirm model selection

* Range for TSS, permanganate, contaminant alarms, spectral fingerprint, and custom alarms are site specific, contact Real Tech for details

* Higher maximum range possible with use of Dilution System option

CONTROLLERS

PRODUCT #	NAME	DESCRIPTION
S-169000	Real Controller	Wall mounted controller with 4-line x 20-character back lit LCD display for sensors
S-11TPC	Real Controller Pro	Wall mounted controller with touch panel PC interface (PC inside cabinet model)
S-11TPCD	Real Controller Pro	Wall mounted controller with touch panel PC interface (PC external on door model)

ACCESSORIES

PRODUCT #	NAME	DESCRIPTION
UVT-078130	Real Clean System I	Automatic chemical cleaning system for use with 2000 and 3000 series models
UVT-118010	Real Clean System II	Automatic chemical cleaning system for use with 4000 series models
UVT-079121	Pump Clean System I	Self-priming pump and automatic chemical cleaning for use with 2000 and 3000 series models
UVT-129122	Pump Clean System II	Self-priming pump and automatic chemical cleaning for use with 4000 series models
S-159124	Air Purge Clean System I	Automatic chemical cleaning, air purge and pump (vertical lift less than 8 ft and pumping distance less than 25ft)
S-179125	Air Purge Clean System II	Automatic chemical cleaning, air purge and booster pump (vertical lift exceeds 8ft or pumping distance exceeds 25 ft)
S-179126	Air Purge Clean System III	Automatic chemical cleaning and air purge. Client supplies pump or water is pressurized
S-169092	Dilution System I	Dilution system, automatic chemical cleaning, air purge and pump (vertical lift less than 8 ft and pumping distance less than 25ft)
S-179093	Dilution System II	Dilution system, automatic chemical cleaning, air purge and booster pump (vertical lift exceeds 8ft or pumping distance exceeds 25 ft)
S-179094	Dilution System III	Dilution system, automatic chemical cleaning and air purge. Client supplies pump or water is pressurized
S-1789121	Dual Feed II	Dual feed option includes Digital I/O module for use with controllers

Real Tech Inc.

1150 Champlain Court,
Whitby, Ontario L1N 6K9 Canada
TF: 1.877.779.2888 T: 1.905.665.6888
info@realtechwater.com

REALTECH
INC.